

SPECIFICATION

RevNo Revision note

Date

Signature

Checked

TIMBER

TREATMENT

CASTING

SUPPLY

HARDWARE

FREE OF HEART . - SPOTTED GUM.

PRESSURE TREATED WITH TANALISED ECOWOOD.

LIFETIME GUARANTEE AGAINST TERMITES AND DECAY.

NIL REQUIRED.

FULLY ASSEMBLED OR PART ASSEMBLED.

STAINLESS STEEL BATTEN SCREWS / HOT DIP GALVANISED /

VANDAL RESISTANT SCREWS.

FIRE PROTECTION

VANDALISM

SELECT HARDWOOD OVER PINE

SELECT HARDWOOD OVER PINE

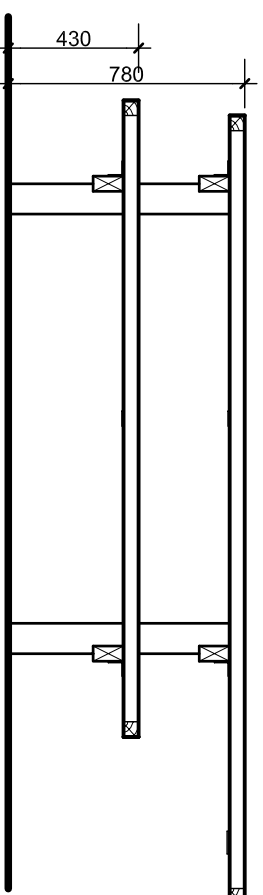
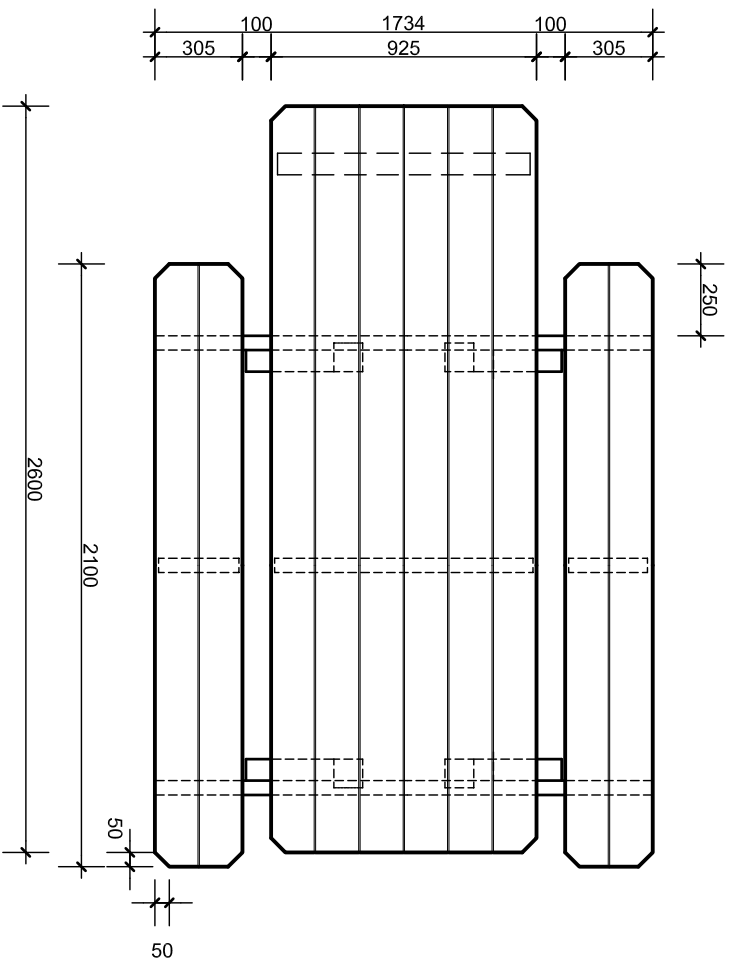

SIDE ELEVATION

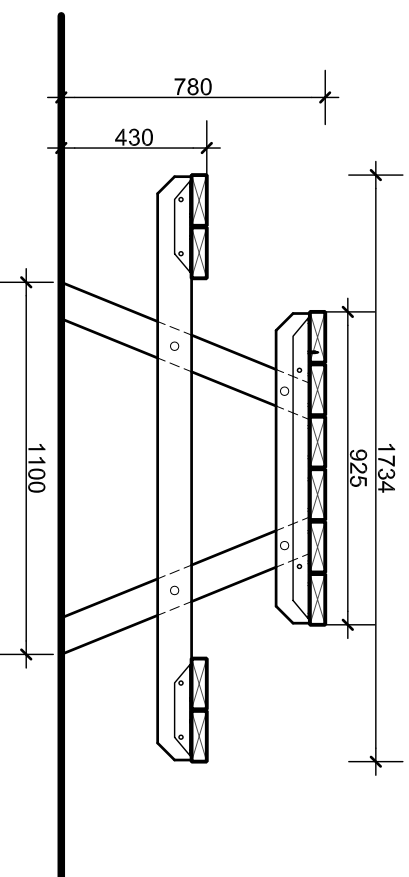

END ELEVATION

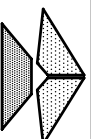

Outdoor Structures Australia
Practical solutions that enhance community design projects

Old College Road, Gattion, Queensland, Australia
PO Box 517, Gattion, Queensland, Australia, 4343
Ph: (07) 5462 4255 Fax: (07) 5462 4077
Email: timber.talk@unq.net.au Website: www.outdoorstructures.com.au

Description

OUTDOOR STRUCTURES AUSTRALIA

HARDWOOD FURNITURE

BLACKLAND RANGE BARBEQUE TABLE

MODEL HD-007B

Scale Job No

NOT TO SCALE OSA

Drawing No
HD-007B

Date

FEB 2007

Drawn

E.M.S.

Approved

E.M.S.