

# OUTDOOR STRUCTURES

*Outlasts and outperforms*

## March 2015 Newsletter

Written by Ted Stubbersfield

[Standards You Can Drive a Bus Through](#)  
[A Real Life Ghost Story](#)

[Flinders Range Improved and Increased](#)  
[Council and State Government Readers](#)

[CPD Points](#)

[Blog for Timber+DESIGN Web Magazine](#)

[Books by Ted](#)

[Bridge Quotes](#)

Dear Reader

[Standards You Can Drive a Bus Through](#)



I remember 1974 well, love was in the air and I did my courting on the upper-deck of the 414 bus going from Dorking to Capel in the UK. It is yesterday I can't remember well. On the subject of buses that brings me to of some of the standards that relate to timber. Sadly aspects of them will allow you to drive the 414 bus through them. Let us consider one of these bus routes.



AS 2082-2007 has a limitation to the amount of lyctus susceptible sapwood that can be supplied in any given piece timber which for most grades is 20% of the cross sectional area. This was overridden by Queensland and New South Wales in their respective timber utilisation acts which would not allow any susceptible sapwood to be supplied. These were acts with real teeth and because of that we did not breach them. Then in their wisdom both governments repealed their acts and the protection that went with them. The image on the right probably now meets the requirements of F14 in Queensland and New South Wales. Are you happy to specify such material?



Not all sapwood is lyctus susceptible and doesn't get turned to powder from the larvae but that does not change the fact that it is not durable if used externally. The image above shows decay in blackbutt sapwood. When the piece was freshly cut the sapwood is clearly visible but as it dries it is hard to tell sapwood from heartwood. Used internally as an exposed beam it will not give you any problems. Move it outside and had it been fitted into a joist hanger the potential for trouble is enormous. Now AS 2082-2007 has no limitation on the amount of sapwood if the timber is not lyctus susceptible.

So, when I went to companies and offered them proprietary products that took the mystery out of specifying timber and I was met with the response "We only specify Australian Standard products" I smiled and thought of the 414 bus. How foolish of me to provide solutions to problems they weren't



aware of. There is a lesson here, ensure all your external timber is treated to H3. Another lesson is the value of a consultancy by myself even if it is just to cast an eye over timber detailing.

Many thanks to the individuals who supplied the images. Want to know more? purchase my book on timber grading.

### [A Real Life Ghost Story](#)



When I wasn't on the 414 I spent a few years in England training for an entirely different profession. One night I slept in a magnificent Louis 16th fourposter that came complete with its own resident poltergeist. I barely slept a wink that night. Not because of any banging of doors and rattling of chains but because of the uncomfortable round bolster pillow. I could understand a member of the French nobility with a seriously sore neck coming back and haunting that bed! (Forgive my poor attempt at humor, the situation was actually very serious).

That brings us to the subject of ghosting. A friend's friend had problems with white marks coming through the varnish on some stairs. "Ghosting," the owners were told by the painters, "not our responsibility" and you will have to pay a vast sum for it to be sanded back and re-coated. A closer look and you can clearly see a workman's boot mark. This appears to be damage to the film due to exposure to contaminants during drying of the coating. This can occur in two ways. If someone walked on the freshly sanded timber with contaminated shoes before coating or sometime after coating when the film may have been dry to touch but not cured. From that one image it is difficult to say which except that the marks are on the stringer too. So we either have a case of the headless workman busy in the witching hour or more likely the careless workman whose mind was not connected to his feet. Much the same thing when you think about it.

To help avoid this happening the Wood Flooring Association suggest

1. Seal the newly laid timber floor with the intended first coat (sealer or finish) prior to exposure to other trades etc. This will protect the timber from most substances, and as the coating used is the same as or

compatible with the first coat being used there will not be any coating system issues. It is however important to address any acclimatisation issues prior to the application of the first coat.

2. Where an instance is likely or has previously occurred, suggest that the windows or glass providing the UV exposure are polarized or UV filter film is applied before finishing/refinishing, or as soon as possible afterward.

Here are some helpful

links [http://www.atfa.com.au/downloads/42\\_Ghosting.pdf](http://www.atfa.com.au/downloads/42_Ghosting.pdf) and [http://www.woodflooringassociation.com.au/login/downloads/%281%29Data\\_Sheet\\_Ghosting\\_March08.pdf](http://www.woodflooringassociation.com.au/login/downloads/%281%29Data_Sheet_Ghosting_March08.pdf)

## Another Addition to the Flinders Range

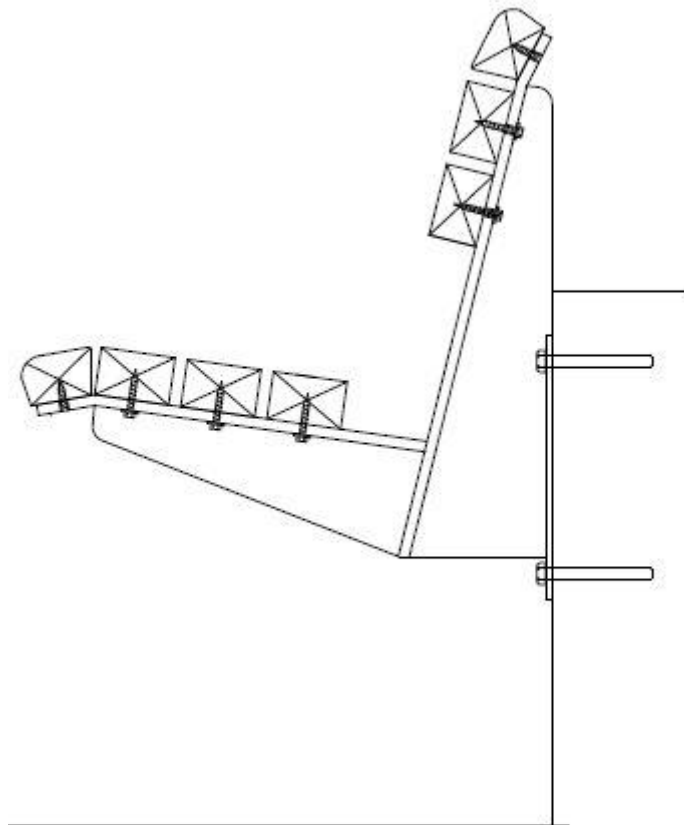

[January's newsletter](#) showed the [Flinders seat](#) both as stand alone or in conjunction with our Continuum shelter. [In February we showed additions to the range.](#) We have now added another seat, This one bolts onto a wall. If you go to the [designers tools section of our website](#) you will find a pdf and dwg file.

## Council and State Government Readers



The end of the financial year will soon be upon us. Don't let your hard fought budget go back to the accountant through funds not being spent. We are very willing to help you with your needs for bridges, shelters, barbecue tables, seats and bollards and of course, Tanacoat. Call myself on 0414770261 and

Keith Smith on 0403 601 030. Avoid the last minute frenzy. In case you had not noticed, the Flinders barbecue table shown above would grace any council park.

## Timber Induction Course eligible for CPD Points



Those offices that have been using my CPD services have found them useful and keep asking me to come back. These are serious talks with [serious learning outcomes with a test at the end](#). Ring me for a

quote on 0414 770261. The image was taken a few years back when i was lecturing to Architects in Addis Ababa University. I thoroughly enjoy doing it. Subjects available are:

Timber Preservation.  
Hardwood Grading.  
Timber Decks – Designing for Durability,  
Utilising Small Diameter Hardwood.  
The Seven Deadly Sins of Timber Design. And the latest,

Joints

## **Bridge Quote Requests**

If there is any doubt that OSA make the best kit bridges in the country look at the [Berrinba Wetlands Project](#) . Not all bridges are equal. After encountering three bridges in one month that did not meet the Bridge Code I wrote the [May 2012 newsletter](#). Refer to it when assessing the suitability of quotes.

[Steel bridge Quotation Request Form](#)

[Timber Bridge Quotation Request Form](#)

### **More information:**

If you have timber road/rail/heritage bridge issues,

we suggest you talk to:

Mr. Dan Tingley  
Senior Engineer  
Wood Research and Development  
1760 SW 3rd Street,  
Corvallis OR 97333  
Office 0011 1 541 752 0188  
Fax: 0011 1 541 752 0195  
Cell: 04 5957 6314 Or 04 28983328  
dant.tingley@gmail.com

## **Outdoor Structures Australia**

E-Mail: [Ted@outdoorstructures.com.au](mailto:Ted@outdoorstructures.com.au)

Web:[www.outdoorstructures.com.au](http://www.outdoorstructures.com.au)

Phone: (07) 5462 4255

Fax (07) 5462 4077

Old College Road Gatton, Australia

PO Box 517 Gatton Q 4343

Australia

ABN 60 152 463 020